



# Sauer Compressors



**Specialist  
for missing pieces**

**FOR INDUSTRY**

**Dependable up to 500 bar – anywhere, anytime.**





Parents know what their children want – even without words. It's apparent from the look in their eyes.

It's the same in the world of compressors: local habits and technical demands are not unique in the world. Our sister companies, agents and dealers speak the local language and provide solutions adapted to the local needs based on high quality products produced by **J.P. Sauer & Sohn Maschinenbau GmbH** in Kiel and **Sauer Žandov A. s.** in the Czech Republic.

Sauer's own companies **Girodin-Sauer SAS** in France, **Sauer Compressors USA Inc.** in the United States, **Sauer do Brasil – Serviços para Compressores Ltda.** in Brazil and the joint venture **ELGI Sauer Compressors Ltd.** in India provide optimum solutions when it comes to application engineering and customer service.

Our sales and service offices **Sauer Compressors UK** in the United Kingdom, **Sauer Compressors Italy** in Italy, **Sauer Compressors China** in China, **Sauer Compressors CIS** in Russia and **Sauer Compressors Singapore** provide local support and understand our customers' needs with a blink of an eye.



You will find our authorized distributors and servicepartners all over the world:  
[www.sauercompressors.com](http://www.sauercompressors.com)

---

**J.P. Sauer & Sohn Maschinenbau GmbH**  
Kiel, Germany  
*Headquarters and Centre of Excellence  
of the Sauer Group  
Production, Packaging, Sales & Service*

**Sauer Žandov A. s.**  
Zandov, Czech Republic  
*Production*

**Girodin-Sauer SAS**  
Paris, France  
*Production, Packaging, Sales & Service*

**Sauer Compressors USA Inc.**  
Stevensville, Maryland, USA  
*Packaging, Sales & Service*

**ELGI Sauer Compressors Ltd.**  
Coimbatore, India  
*Production, Packaging, Sales & Service*

**Sauer do Brasil  
Serviços para Compressores Ltda.**  
Rio de Janeiro, Brazil  
*Packaging, Sales & Service*

**Sauer Compressors UK**  
Colchester, United Kingdom  
*Sales & Representative Office*

**Sauer Compressors China**  
Shanghai, China  
*Sales & Representative Office*

**Sauer Compressors Italy**  
Lecco, Italy  
*Sales & Representative Office*

**Sauer Compressors CIS**  
Moscow, Russia  
*Sales & Representative Office*

**Sauer Compressors Singapore**  
Singapore  
*Sales & Representative Office*

## Compressor and Capacity Range

	<ul style="list-style-type: none"> <li>■ <b>MISTRAL</b> series</li> <li>Pressure range: 8–40 bar(g)</li> <li>Variants: Basic, BasBooster<sup>®</sup>, BasBooster<sup>®</sup>, ComSilent, ComDry, ComBooster<sup>®</sup>, ComBooster<sup>®</sup></li> <li>Medium: Air, Nitrogen</li> </ul>	
	<ul style="list-style-type: none"> <li>■ <b>PASSAT</b> series</li> <li>Pressure range: 10–80 bar(g)</li> <li>Variants: Basic, BasBooster<sup>®</sup>, BasSeal<sup>®</sup>, ComSilent, ComDry, ComBooster<sup>®</sup>, ComSeal<sup>®</sup></li> <li>Medium: Air, Nitrogen, Helium, Natural gas, Hydrogen</li> </ul>	
	<ul style="list-style-type: none"> <li>■ <b>TYPHOON</b> series</li> <li>Pressure range: 10–100 bar(g)</li> <li>Variants: Basic, BasBooster<sup>®</sup></li> <li>Medium: Air, Nitrogen</li> </ul>	
	<ul style="list-style-type: none"> <li>■ <b>HURRICANE</b> series</li> <li>Pressure range: 50–400 bar(g)</li> <li>Variants: Basic, BasBooster<sup>®</sup>, BasSeal<sup>®</sup>, BasBreath, ComSilent, ComDry, ComBooster<sup>®</sup>, ComSeal<sup>®</sup>, ComBreath</li> <li>Medium: Air, Nitrogen, Helium, Natural gas, Bio-methane, Hydrogen</li> </ul>	
	<ul style="list-style-type: none"> <li>■ <b>TORNADO</b> series</li> <li>Pressure range: 50–400 bar(g)</li> <li>Variants: Basic, BasBreath, BasBooster<sup>®</sup>, ComSilent, ComDry, ComBooster<sup>®</sup>, ComBooster<sup>®</sup>, ComSeal<sup>®</sup>, ComBreath</li> <li>Medium: Air, Nitrogen, Helium, Natural gas</li> </ul>	
	<ul style="list-style-type: none"> <li>■ <b>5000</b> series</li> <li>Pressure range: 50–400 bar(g)</li> <li>Variants: Basic, BasBooster<sup>®</sup></li> <li>Medium: Air, Nitrogen</li> </ul>	
	<ul style="list-style-type: none"> <li>■ <b>6000</b> series</li> <li>Pressure range: 16–500 bar(g)</li> <li>Variants: Basic, BasBooster<sup>®</sup>, BasBooster<sup>®</sup>, BasSeal<sup>®</sup></li> <li>Medium: Air, Nitrogen, Helium, Natural Gas, Bio-methane</li> </ul>	

### Sauer air compressor range

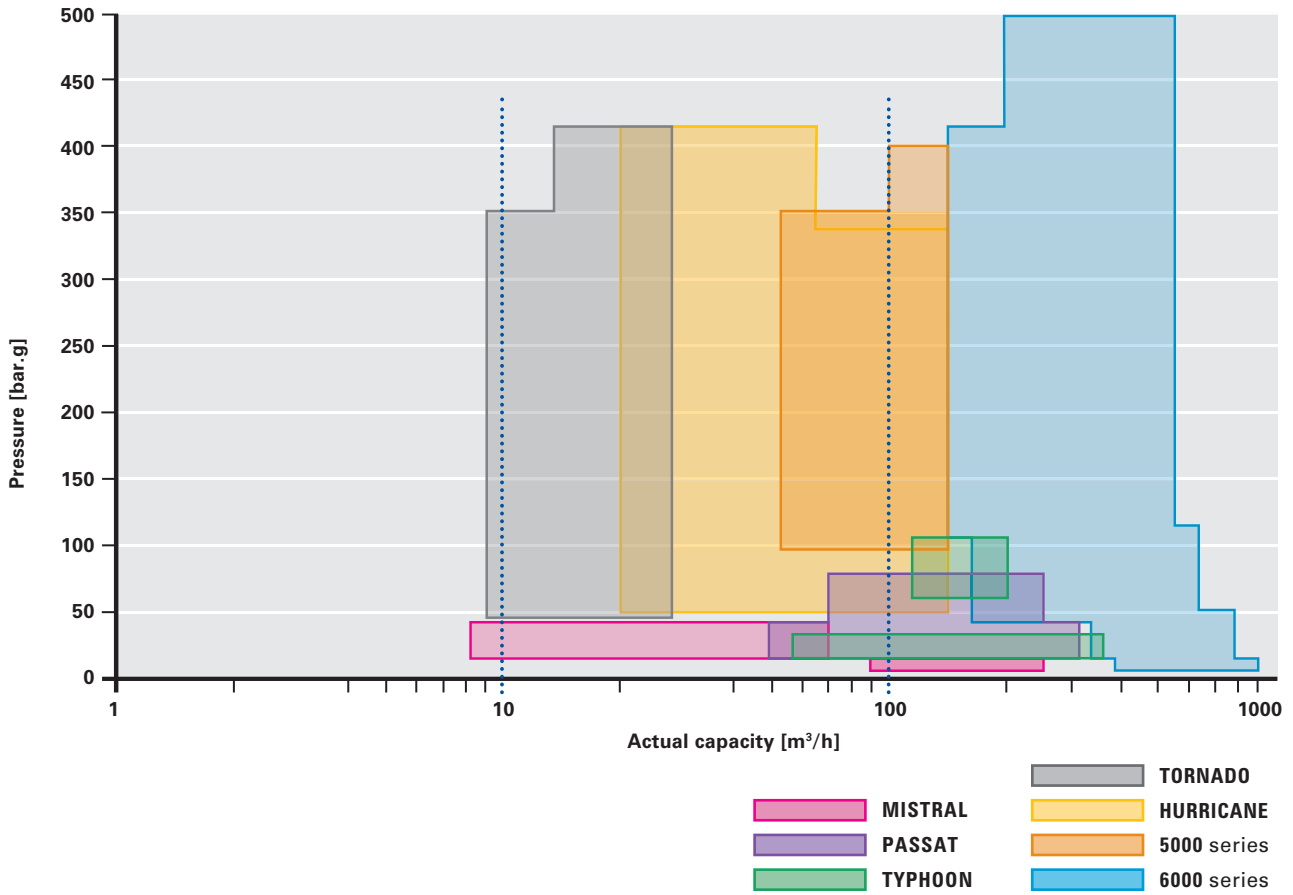

### Sauer gas booster range

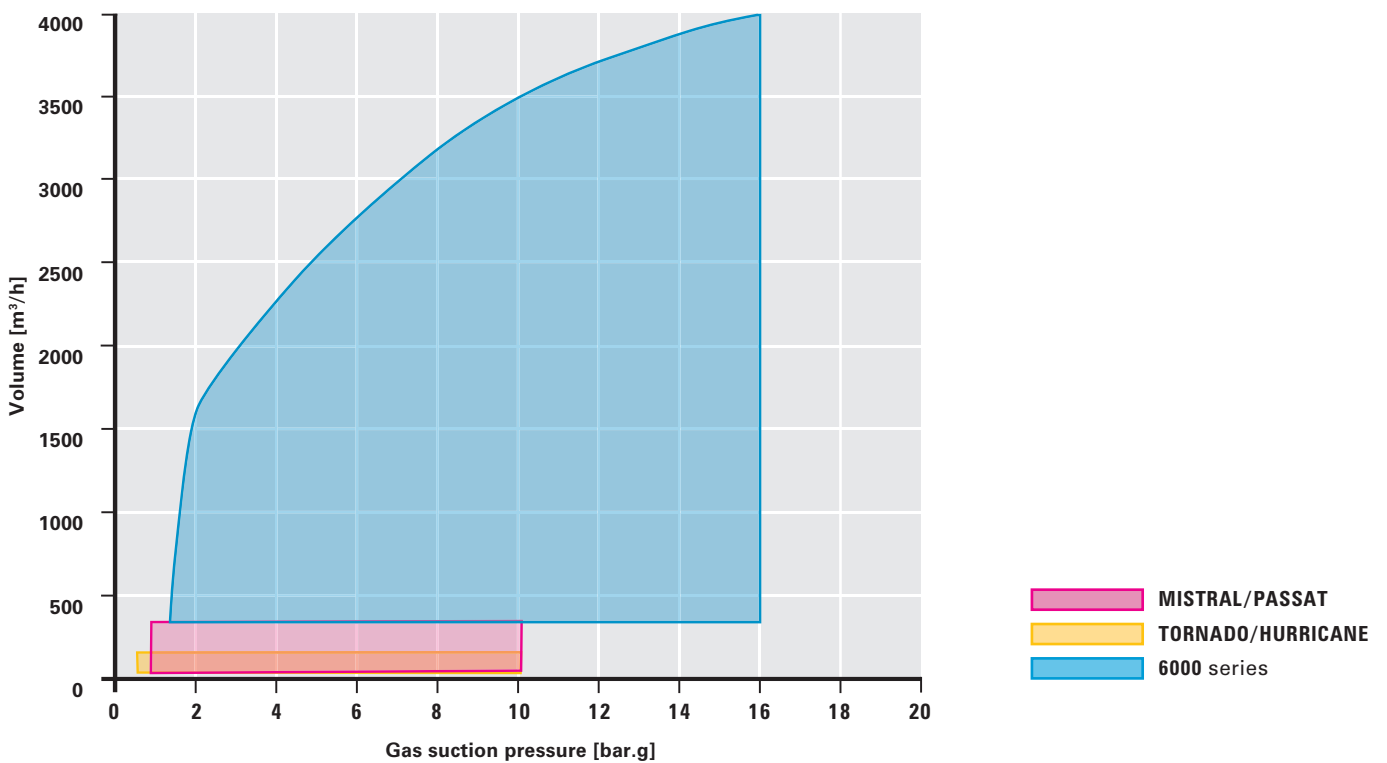

## Power Generation

**For decades now**, Sauer compressors have been operating reliably in power plants of all types throughout the world – regardless of whether they operate continuously or in start/stop mode. At the same time, the volume flows and pressure ranges are tailored to the specific needs of our customers. Indeed, Sauer is always happy to take into account customers' individual requirements and is able to cater for (virtually) any request.

**Our customers benefit from the following advantages:**

- The very latest compressors, control systems, compressed-air treatment systems and accessories
- Optimum customer services starting with the initial enquiry and extending over the entire life of the product
- 100% compressor check at final pressure including 3.1 inspection certificate
- Long operating life with guaranteed availability of replacement parts (minimum 25 years)
- Turn-key solutions produced in accordance with customers' specifications
- Customer-specific documentation and calculations
- Trouble-free operation, even under the most extreme conditions (55°C ambient temperature)
- Individual, customer-oriented service concepts

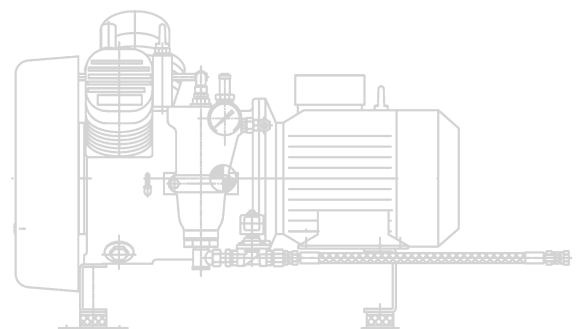



## Diesel-engine generators

Diesel-engine generators (also known as gen-sets) consist of a diesel engine and a generator. Given that they provide an independent means of generating electricity, they are a popular choice at production sites in remote areas or as emergency power supplies for major banks, hospitals, airports and even entire towns or cities. Indeed, a number of countries and island states produce the majority of their electricity using diesel-engine generators.

### What are Sauer compressors used for?

- Starting air
- DENOX treatment

### Who are Sauer Compressors' customers?

- Power-plant operators
- Diesel-engine manufacturers
- Engineering offices
- Contractors

### Which Sauer product ranges are used?

- Product ranges: MISTRAL, PASSAT, 6000
- Variants: Basic, ComSilent
- Volumetric flow: 10 – 485 m<sup>3</sup>/hr
- Pressure range: 15 – 50 bar (g)
- Medium: Air

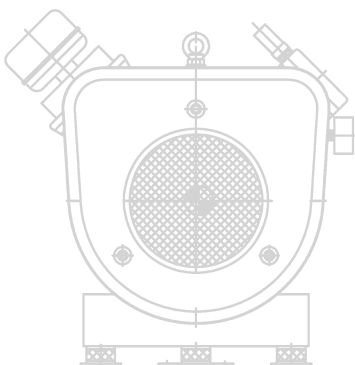

## Power Generation



### Gas-turbine power plants, combined heat and power plants

In gas-turbine power plants, flammable gases are used to drive turbines. These turbines are in turn connected to generators which actually produce the electricity. In gas and steam combination power plants, the heat generated by the gas turbines is also used to produce steam for the steam turbines. Small gas power plants (so-called combined heat and power plants) use an internal combustion engine instead of a turbine to drive the generator. These combined heat and power plants are frequently used in order to cover periods of peak demand within the electricity network.

#### What are Sauer compressors used for?

- Starting air
- Purging air
- Sealing gas (nitrogen)
- Feeding in gas

#### Who are Sauer Compressors' customers?

- Power-plant operators
- Turbine manufacturers
- Engineering offices
- Contractors

#### Which Sauer product ranges are used?

Product ranges: MISTRAL, PASSAT, TYPHOON, 6000

Variants: Basic, ComSilent, BasSeal, ComSeal

Volumetric flow: 100 – 1000 m<sup>3</sup>/hr

Pressure range: 15 – 50 bar (g)

Medium: Air, nitrogen

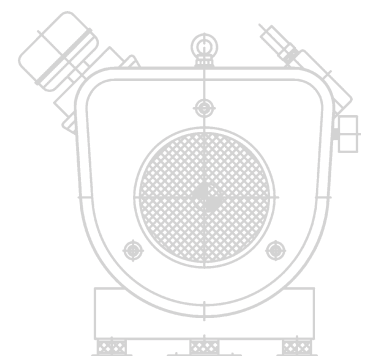





## Steam power plants, coal-fired power plants, waste incineration facilities

In steam power plants, the thermal energy contained in water vapour is used to power a steam turbine which in turn drives the generator. In the process, conventional fuels such as oil, natural gas, hard coal or brown coal are used to fire the steam boiler. In coal-fired power plants, coal is the only fuel used, whereas waste incineration facilities can also use treated waste in order to generate electricity.

### What are Sauer compressors used for?

- Desulphurisation
- Removing fuel residues (soot blowing)
- DENOX treatment
- Cooling the turbines using hydrogen

### Who are Sauer Compressors' customers?

- Power-plant operators
- Turbine manufacturers
- Engineering offices
- Contractors

### Which Sauer product ranges are used?

Product ranges: MISTRAL, PASSAT, HURRICANE, 6000

Variants: Basic, ComSilent

Volumetric flow: 100 – 1000 m<sup>3</sup>/hr

Pressure range: 15 – 250 bar (g)

Medium: Air, hydrogen

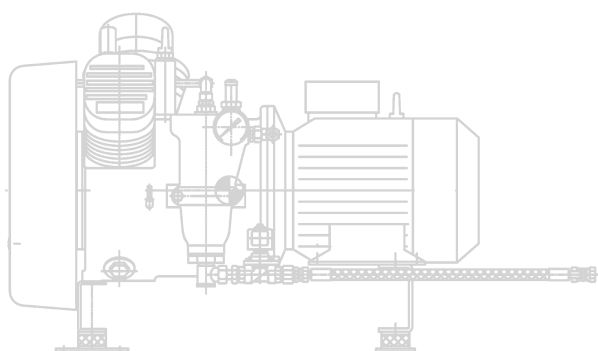

## Power Generation

### Hydroelectric power plants and other hydroelectric facilities

In hydroelectric power plants, the mechanical energy of the water is converted into electrical current using turbines and generators connected to them. Given that the effective head varies, a distinction is made between low, medium and high-pressure power plants. Similarly, there are run-of-river plants as well as storage plants (including pumped-storage plants) depending on the way in which the available water is used.

#### What are Sauer compressors used for?

- Braking air for pneumatic brakes
- Adjusting turbine blades and large valves (e. g. governor)
- Blowing air (blowing out the water to eliminate the load during starting)
- Preventing pulsation and cavitation

#### Who are Sauer Compressors' customers?

- Power-plant operators
- Turbine manufacturers
- Engineering offices
- Contractors

#### Which Sauer product ranges are used?

Product ranges: MISTRAL, PASSAT, TYPHOON, 6000

Variants: Basic, ComSilent

Volumetric flow: 50 – 600 m<sup>3</sup>/hr

Pressure range: 30 – 100 bar (g)

Medium: Air, nitrogen





## Nuclear power plants, atomic power plants

Although they belong to the group of steam power plants, nuclear power plants are mentioned here separately as they obtain the energy they need to heat steam through splitting atoms rather than through burning fossil fuels.

### What are Sauer compressors used for?

- Starting air for emergency power for the diesel engines
- Cooling the turbines using hydrogen
- Cooling the reactor core using hydrogen

### Who are Sauer Compressors' customers?

- Power-plant operators
- Diesel-engine manufacturers
- Engineering offices
- Contractors

### Which Sauer product ranges are used?

Product ranges: MISTRAL, PASSAT, HURRICANE, TORNADO

Variants: Basic, ComDry, BasSeal, ComSeal

Volumetric flow: 10 – 265 m<sup>3</sup>/hr

Pressure range: 30 – 250 bar (g)

Medium: Air, hydrogen

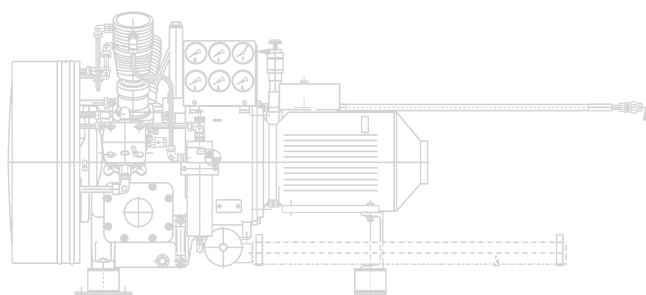
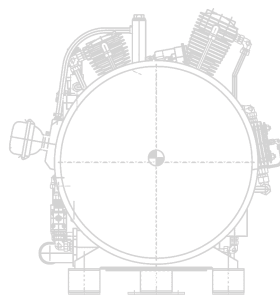

## Power Distribution

**One of the first Sauer industrial compressors** was used to extinguish electrical arcs in electrical substations. Since this sale back in 1956, we have made constant efforts not only to expand and develop our expertise but also to invest it in the compressors themselves. As a result, Sauer is now one of the best-known suppliers for electrical substations – an application requiring safe and reliable operation given the extreme conditions encountered. Sauer offers reliable solutions for renewable energies too, for example the distribution of bio-methane in order to generate electricity. With its gas-tight compressors built to individual customer specifications, Sauer is one of the forerunners within this sector. Indeed, Sauer is always happy to take into account customers' individual requirements and is able to cater for (virtually) any request.

### Our customers benefit from the following advantages:

- The very latest compressors, control systems, compressed-air treatment systems and accessories
- Optimum customer services starting with the initial enquiry and extending over the entire life of the product
- 100 % compressor check at final pressure including 3.1 inspection certificate
- Long operating life with guaranteed availability of replacement parts (minimum 25 years)
- Turn-key solutions produced in accordance with customers' specifications
- Customer-specific documentation and calculations
- Great reliability, even during intermittent operation
- Individual, customer-oriented service concepts



## Air and gas distribution

What would an infrastructure be without systems to distribute the energy sources available? Sauer Compressors deals not only with local compressed-air networks and natural-gas networks but also with renewable energies. With its expertise and understanding of its customers' requirements, Sauer is able to provide the optimum solution to a particular problem. Customer-specific solutions with gastight compressors, turn-key systems and container stations are therefore part of the typical range of products which the company offers.

### What are Sauer compressors used for?

- Starting air
- Desulphurisation
- Feeding biomethane into the national and international network
- Recovering gas lost as a result of leakage
- Feeding natural gas and air into the relevant networks

### Who are Sauer Compressors' customers?

- Energy-supply companies
- Gas-station manufacturers
- Gas-treatment companies
- Engineering offices

### Which Sauer product ranges are used?

Product ranges: PASSAT, HURRICANE, 6000  
 Variants: Basic, BasSeal, ComSeal  
 Volumetric flow: 50 – 2000 m<sup>3</sup>/hr  
 Pressure range: 16 – 350 bar (g)  
 Medium: Air, bio-methane, natural gas



## Electrical substations

Part of a country's electricity supply network, electrical substations are operated by energy supply companies and are used to change the voltage levels. The optimum voltage is selected according to the level of power which is to be transmitted and the distances over which the electricity must travel. Electrical substations are in use within national and regional transmission networks (usually in the form of open-air facilities) as well as district and local distribution networks (usually in the form of indoor facilities). Transformer stations are the final link in the chain which provides the lower voltage required by consumers.

### What are Sauer compressors used for?

- Extinguishing electrical arcs
- Actuating open power switches

### Who are Sauer Compressors' customers?

- Energy-supply companies
- Major industrial companies which have their own electrical substations
- Local operators of electrical substations
- Engineering offices

### Which Sauer product ranges are used?

Product ranges: MISTRAL, PASSAT, HURRICANE, TORNADO  
Variants: Basic, ComSilent  
Volumetric flow: 10 – 300 m<sup>3</sup>/hr  
Pressure range: 30 – 100 bar (g)  
Medium: Air



## Processing Industry

**One of the most extensive** and at the same time varied areas of use for Sauer compressors is the processing industry. With the help of Sauer's medium and high-pressure compressors, materials and other substances can be converted, shaped, blended, cast or pressed. With its reliable, economical compressors as well as its knowledge and understanding of the overall processes involved, Sauer is the ideal partner when it comes to finding solutions for individual applications.

### Our customers benefit from the following advantages:

- The very latest compressors, control systems, compressed-air treatment systems and accessories
- Optimum customer services starting with the initial enquiry and extending over the entire life of the product
- 100% compressor check at final pressure including 3.1 inspection certificate
- Long operating life with guaranteed availability of replacement parts (minimum 25 years)
- Compressors designed for permanent operation (S1 – 24/7)
- Minimal downtimes ensuring high product availability
- MTBF ↑, MTBO ↑, MTTR ↓
- Optimum service concepts

## Checking and testing

All products which are to be used under a certain pressure must undergo initial testing at a pressure which is many times greater than that required. If necessary, their gastightness must also be checked when using highly volatile gases. Although water was previously used to carry out pressure checks, an improved procedure involving air, nitrogen or helium is now used instead. During leakage checks, Sauer compressors help to recycle the gas which escapes, e. g. helium, and then return it to the process. The advantages are plain to see. Individual process steps, for example cleaning and drying during water checks, are shortened or can be dispensed with entirely. In addition, the loss of expensive gases can be avoided.

### What are Sauer compressors used for?

- Checking brakes and other components under pressure
- Checking airbags and other components under pressure
- Checking injection systems under pressure
- Checking the gastightness of components using helium
- Checking valves and other fittings under pressure
- Checking containers under pressure
- Checking of coolant containers and heat exchangers

### Who are Sauer Compressors' customers?

- Automotive manufacturers
- Automotive suppliers
- Manufacturers of valves and other fittings
- Manufacturers of pressurised containers

### Which Sauer product ranges are used?

Product ranges: PASSAT, HURRICANE, 6000  
 Variants: BasBooster, ComBooster, BasSeal, ComSeal  
 Volumetric flow: 50 – 2000 m<sup>3</sup>/hr  
 Pressure range: 20 – 420 bar (g)  
 Medium: Air, nitrogen, helium





## Metal treatment

The fact that modern manufacturing procedures speed up processes and are therefore more efficient and less expensive, means that they offer an important competitive advantage. In the field of metal treatment, it is Sauer compressors which allow you to benefit from this advantage. Working together with our customers, we develop innovative, integrated system solutions, i. e. systems which allow you not only to supply a process with gases but also to remove them again and store them for use in the next step. Users also benefit from the particularly low leakage rates of our gas compressors and from our turn-key installations, some of which have a flexible design.

### What are Sauer compressors used for?

- Hardening materials

### Who are Sauer Compressors' customers?

- Automotive suppliers
- Aviation suppliers
- Manufacturers of hardening furnaces
- Autoclave manufacturers

### Which Sauer product ranges are used?

Product ranges: PASSAT, HURRICANE

Variants: BasSeal, ComSeal

Volumetric flow: 50 – 200 m<sup>3</sup>/h

Pressure range: 20 – 40 bar (g)

Medium: Air, nitrogen, helium

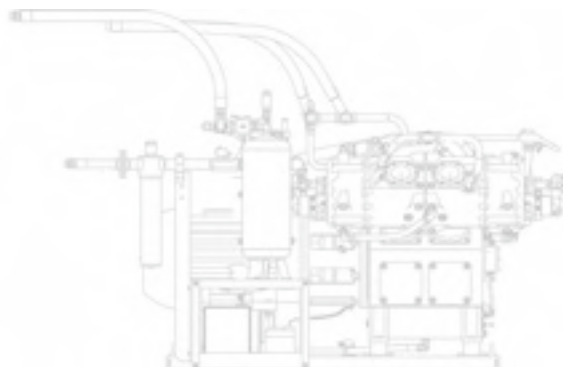



## Laser metal cutting

The cutting of metals with the help of a laser has replaced traditional mechanical methods and offers clear advantages. For example, the processes involved are shortened and the cut surfaces are not contaminated by the material of the cutting dies. However, the laser environment must be free from ambient air if an optimum cut is to be achieved. To ensure that this is the case, nitrogen is used. This nitrogen is preferably produced on site using the pressure swing adsorption (PSA) process or membranes. This helps to ensure that companies are not reliant on gas suppliers. After the PSA process has been carried out, Sauer compressors are used to boost the nitrogen to a pressure of 40 or 300 bar.

The higher pressure of 300 bar offers particular advantages as it enables large amounts of gas which are normally sufficient for a number of days to be stored quickly. Not only do users benefit from greater operational reliability, they do not need to operate their high-pressure compressor for such long periods and can therefore take advantage of the times where cheaper energy tariffs apply. In addition, a great deal less extra equipment is required upstream when a pressure of 300 bar is used.

### What are Sauer compressors used for?

- Creating an inert atmosphere surrounding the laser

### Who are Sauer Compressors' customers?

- Metal treatment companies
- Manufacturers of machine tools for laser cutting
- Manufacturers of nitrogen generators/nitrogen membranes

### Which Sauer product ranges are used?

Product ranges: MISTRAL, HURRICANE , TORNADO

Variants: BasBooster, ComBooster

Volumetric flow: 10 – 100 m<sup>3</sup>/hr

Pressure range: 20 – 300 bar (g)

Medium: Nitrogen

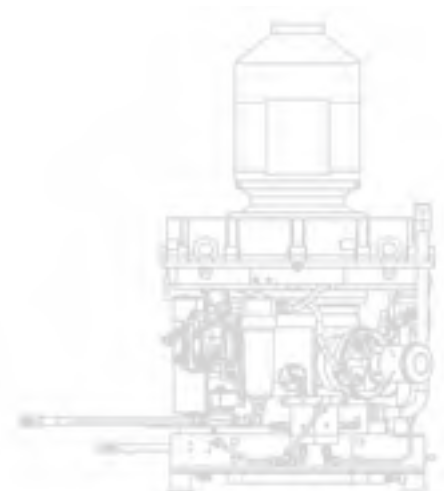





## Plastic forming

In the complex field of plastic forming, more and more customers are relying on Sauer compressors given their reliability and the uncomplicated, rapid service offered by the company. In this sector, it is particularly important to have a continuous supply of compressed air available in order to avoid production downtime. For mass production (where many of our customers operate), failure to produce the required number of units can ultimately decide whether or not a company can continue to exist. With its 24/7 design, the Sauer compressor is able to operate even in the most difficult environmental conditions and is therefore the ideal compressor to meet the requirements of customers in this particular sector.

### What are Sauer compressors used for?

- Internal gas-pressure procedures
- Isostatic forming
- Manufacturing PET bottles/  
PET canisters

### Who are Sauer Compressors' customers?

- Manufacturers of mobile telephones
- Automotive suppliers
- Manufacturers of housings for electronic goods
- Manufacturers of plastic bottles for drinks, oils, shampoos etc.
- Manufacturers of internal gas-pressure systems

### Which Sauer product ranges are used?

Product ranges: PASSAT, HURRICANE, TORNADO, 6000

Variants: Basic, BasBooster, ComSilent,  
ComBooster

Volumetric flow: 10 – 600 m<sup>3</sup>/hr

Pressure range: 40 – 350 bar (g)

Medium: Air, nitrogen

## Processing Industry

### Manufacturing composite materials

The manufacture of composite materials is also part of the processing industry. In both the wooden materials and plastics industry, different materials are pressed together under the influence of pressure and heat in order to produce materials with special characteristic properties. In the field of plastics, so-called autoclaves (special pressurised containers which can be sealed so as to be gastight) are used. Sauer compressors offer an efficient way of ensuring that the necessary pressure is available for these processes.

#### What are Sauer compressors used for?

- Filling and generating pressure for autoclaves
- Raising pressure for wood presses

#### Who are Sauer Compressors' customers?

- Producers of wood-fibre composite materials
- Producers of plastic composite systems
- Manufacturers of autoclaves

#### Which Sauer product ranges are used?

Product ranges: PASSAT, HURRICANE, 6000

Variants: Basic, ComSilent

Volumetric flow: 200 – 600 m<sup>3</sup>/hr

Pressure range: 40 – 150 bar (g)

Medium: Air



## Nitrogen – generation and storage

Nitrogen plays an essential role in many other applications as well. Sauer compressors are a popular choice when it comes to storing large amounts of the gas so that it is available quickly and in sufficient quantities when carrying out the desired processes. There is a good reason for this. Each Sauer gas compressor is engineered to offer the high level of flexibility required to satisfy an extremely wide range of requirements such as different suction pressures, final pressures or gas quality. As a result, they are frequently used in a variety of medium and high-pressure applications.

### What are Sauer compressors used for?

- Creating an inert atmosphere
- Transporting media
- Inflating aircraft tyres
- Filling fire-extinguishing systems

### Who are Sauer Compressors' customers?

- Chemical or gas manufacturers
- Tyre manufacturers
- Manufacturers of fire-extinguishing systems
- Manufacturers of nitrogen generators/membranes
- Service companies to the aircraft industry

### Which Sauer product ranges are used?

Product ranges: PASSAT, HURRICANE, TORNADO, 6000  
Variants: BasBooster, ComBooster  
Volumetric flow: 10 – 2000 m<sup>3</sup>/hr  
Pressure range: 20– 400 bar (g)  
Medium: Nitrogen



## Urea plants

Nowadays urea is recognised as an integral part of many industrial processes and the number of production plants is constantly increasing. In this connection the fertiliser industry takes the largest share: the application of fertilisers is a crucial prerequisite to be able to increase the amount of food produced to match the ever-growing worldwide demand.

### What are Sauer compressors used for?

- Forming a very resistant CrO<sub>3</sub>-layer

### Who are Sauer Compressors' customers?

- Production Plants for Urea (e. g. Fertilizer Plants)

### Which Sauer product ranges are used?

Product ranges: TORNADO, HURRICANE, 6000  
Variants: Basic, ComSilent  
Volumetric flow: 500 – 1000 m<sup>3</sup>/hr  
Pressure range: 150 – 200 bar (g)  
Medium: Air

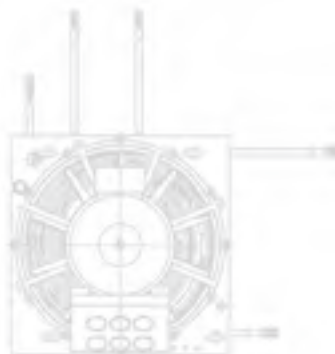

## Research and Development

**Many firms and institutions use Sauer compressors** in a variety of areas when carrying out research and development. Regardless of whether sensitive gases are in use, modern materials are being tested or complex processes play an important role, Sauer compressors are a sound choice for any application, operating without problems for many decades. Customers value our understanding of industrial applications and our ability to come up with exactly the right type of compressor to suit their requirements. For example, the majority of universities rely on Sauer compressors when it comes to helium recovery.

### Our customers benefit from the following advantages:

- The very latest compressors, control systems, compressed-air treatment systems and accessories
- Optimum customer services starting with the initial enquiry and extending over the entire life of the product
- 100% compressor check at final pressure including 3.1 inspection certificate
- Long operating life with guaranteed availability of replacement parts (minimum 25 years)
- Turn-key solutions produced in accordance with customers' specifications
- Great reliability, even during intermittent operation
- Optimum customer and compressor care concepts



## Combustion engine testing

Many customers are familiar with Sauer compressors through their role in shipping, e.g. the starting of diesel engines. However, many people do not realise that Sauer compressors also play an important role in testing these engines and developing new ones. They are therefore widely used on engine test beds. What is more, Sauer compressors can play a role in the development of gas engines such as natural-gas engines too.

### What are Sauer compressors used for?

- Starting air
- Natural-gas storage

### Who are Sauer Compressors' customers?

- Automotive manufacturers
- Engine manufacturers
- Universities

### Which Sauer product ranges are used?

Product ranges: MISTRAL, PASSAT, HURRICANE  
 Variants: Basic, BasSeal, ComSilent, ComSeal  
 Volumetric flow: 50 – 2000 m<sup>3</sup>/hr  
 Pressure range: 30 – 350 bar (g)  
 Medium: Air, natural gas

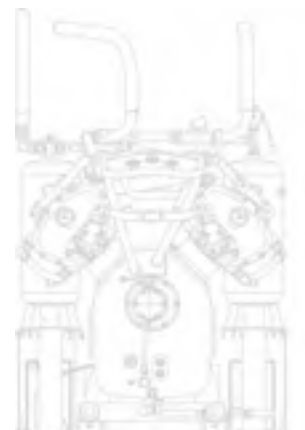



## Research institutions and universities

The fact that universities as well as state and private research institutions carry out extremely demanding work means that they rely on top-quality components in order to achieve highly accurate results. Downtime and extended experimental periods reduce competitiveness and waste funds which have been allocated for research purposes. In the field of helium recovery and liquefaction, Sauer compressors can optimise the process – with a maximum leakage rate of just 0.1 mbar x l/s. Their economical design comes into its own in ultrasound tests in wind tunnels or vehicle crash tests – two applications which require high volumes in an extremely short period. Sauer compressors save time and reduce costs, making it possible to carry out more tests at shorter intervals.

### What are Sauer compressors used for?

- Metrology
- Ultrasound wind tunnels
- Nano-coatings
- Helium recovery
- Crash tests as part of vehicle development

### Who are Sauer Compressors' customers?

- Universities
- Research centres
- Metrological institutions
- Automotive research institutions

### Which Sauer product ranges are used?

Product ranges: PASSAT, HURRICANE, TORNADO, 6000

Variants: Basic, BasSeal, ComSilent, ComSeal

Volumetric flow: 50 – 2000 m<sup>3</sup>/hr

Pressure range: 20 – 420 bar (g)

Medium: Air, helium

## Oil and Gas

**Whether onshore or offshore** – Sauer compressors are used in a variety of applications within the oil and gas sector. Designed for 24/7 operation, their robust construction allows them to be used (virtually) anywhere and under extremely difficult environmental conditions, for example, when exposed to saltwater, heat or cold. Sauer compressors easily satisfy the criteria of nearly all classification societies such as ABS, DNV and GL, whilst complying with a range of other certification systems too. In addition to our standard solutions, we also provide complex solutions which are designed to meet our customers' specifications. These include mobile, container-type units, gastight or explosion-proof designs, units featuring diesel or gas engines and even combinations of all of these.

Sauer compressors always do their job reliably – regardless of whether they are in use on a floating platform in the Gulf of Mexico, in the engine room of a ship off the coast of Vietnam or on a heavy goods vehicle in Siberia.



### Our customers benefit from the following advantages:

- The very latest compressors, control systems, compressed-air treatment systems and accessories
- Optimum customer services starting with the initial enquiry and extending over the entire life of the product
- 100% compressor check at final pressure including 3.1 inspection certificate
- Long operating life with guaranteed availability of replacement parts (minimum 25 years)
- Turn-key solutions produced in accordance with customers' specifications
- Compressors designed for permanent operation (S1 – 24/7)
- Classification and certification in accordance with ATEX, ABS, GL, DNV etc. possible
- Maximum +/-22.5° heeling and longitudinal tilting for mobile concepts

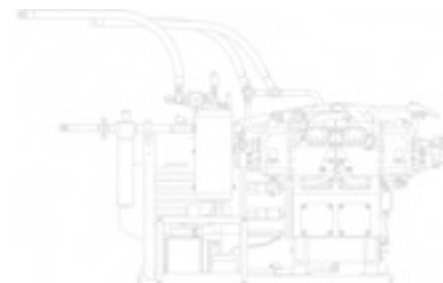

---

## Offshore

Industrial oil and gas consumption is growing throughout the world. This means that new technologies and deposits must constantly be found if this increased demand is to be met. The fact that Sauer compressors are very much at home on ships in general makes them ideal for use onboard exploration vessels which use air guns to survey the seabed around the world with a view to finding and exploiting new deposits. As the only supplier which is able to provide not only the compressors for the air guns but also the compressors for starting diesel engines, Sauer Compressors can offer its customers complete solutions!

Sauer compressors are equally at home on oil platforms too. Our compressors meet the strict requirements imposed within this particular branch of industry. They are used in order to compensate for the natural movement of the sea and thus help to ensure that drilling and production can continue even when the sea is rough. Naturally, we are on hand to assist you even after your compressors have been delivered. Whether they travel by helicopter or by ship, Sauer's service personnel will always get to you somehow.

### What are Sauer compressors used for?

- Air guns/surveying the seabed (Seismic application)
- Motion compensating on board floating crude-oil platforms
- Rig tensioning
- Water hammering
- Subsea

### Which Sauer product ranges are used?

Product ranges: HURRICANE, 5000, 6000  
Variants: Basic, BasBooster, ComSilent, ComBooster  
Volumetric flow: 30–750 m<sup>3</sup>/hr  
Pressure range: 100 – 400 bar (g)  
Medium: Air, nitrogen

### Who are Sauer Compressors' customers?

- Marine research institutions
- Exploration firms
- Platform equipment suppliers



## Oil and Gas



### Pipeline-related services

Sauer compressors are not limited to searching for and producing oil and gas – they are involved in transporting these substances via pipelines too. Sauer compressors in containers mounted on mobile units are used during the construction and subsequent operation of these supply lines. As compact units including diesel engines, Sauer compressors offer important advantages which make them a popular choice.

#### What are Sauer compressors used for?

- Cleaning pipelines
- Checking pipelines

#### Who are Sauer Compressors' customers?

- Petrochemical industry
- Oil-field suppliers

#### Which Sauer product ranges are used?

Product ranges: HURRICANE, 6000

Variants: Basic, ComSilent

Volumetric flow: 30 – 2000 m<sup>3</sup>/hr

Pressure range: 30 – 400 bar (g)

Medium: Air

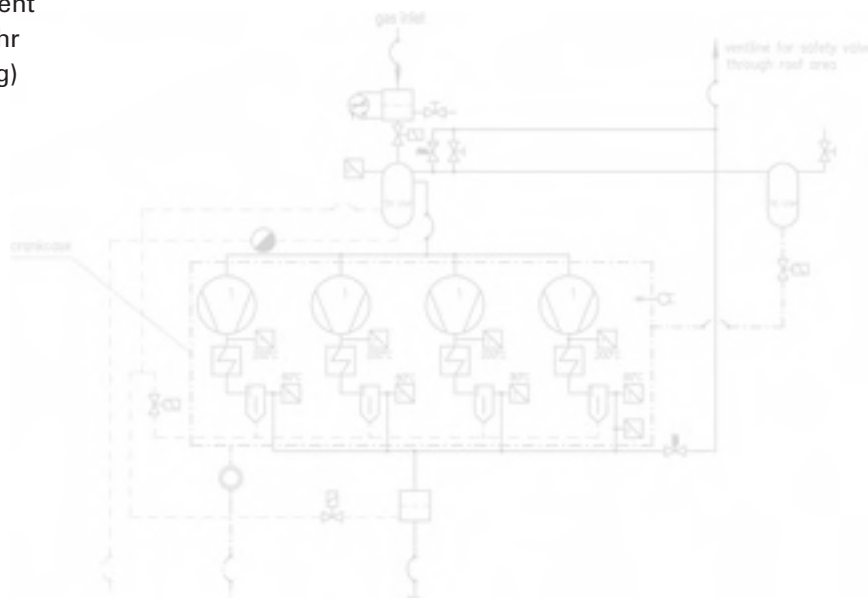





## Nitrogen – generation and storage

Regardless of whether they are located in the desert of Saudi Arabia or in the cold of Siberia, oil fields are usually found in remote areas which lack direct access to the necessary infrastructure. In these harsh environments, Sauer compressors prove their worth on a daily basis – for example when using nitrogen to maintain the discharge pressure of a well or to protect components against other media. Sauer compressors are at home wherever they happen to be needed – for medium and high-pressure applications up to 400 bar, for continuous use and even for short-notice start/stop operation.

### What are Sauer compressors used for?

- Creating an inert atmosphere
- Drilling deep wells
- Drilling systems
- Revitalization of Oil wells

### Who are Sauer Compressors' customers?

- Petrochemical industry
- Oil-field suppliers
- Manufacturers of nitrogen generators/nitrogen membranes

### Which Sauer product ranges are used?

Product ranges: PASSAT, HURRICANE, TORNADO, 5000, 6000

Variants: BasBooster, ComBooster

Volumetric flow: 10 – 2000 m<sup>3</sup>/hr

Pressure range: 20 – 400 bar (g)

Medien: Nitrogen

## Metallurgy

**Medium and high-pressure compressors** are used in a wide variety of metallurgical applications, which encompass the entire range of processes for producing and using metals, metalloids and non-metals. Wherever they happen to be used, Sauer compressors do their job reliably and efficiently. This, combined with their particularly long operating lives even under extreme environmental conditions, makes them more or less indispensable within the field of metallurgy. Indeed, it would not be possible to use many processes were it not for Sauer compressors!

### Our customers benefit from the following advantages:

- The very latest compressors, control systems, compressed-air treatment systems and accessories
- Optimum customer services starting with the initial enquiry and extending over the entire life of the product
- 100% compressor check at final pressure including 3.1 inspection certificate
- Long operating life with guaranteed availability of replacement parts (minimum 25 years)
- Turn-key solutions produced in accordance with customers' specifications
- Robust designs to withstand even the most extreme conditions (55°C ambient temperature)
- Minimal downtimes ensuring high product availability
- Compressors designed for permanent operation (S1 – 24/7)



## Producing and forming steel

Although the production of steel was for a long time the pillar of heavy industry, it is now in the hands of a few major producers based throughout the world. Medium and high-pressure compressors for air and gases play an essential role at steelworks. Indeed, they are used not only to produce the steel itself and alter the carbon content in the blast furnace but also to press the steel into slabs and subsequently treat them. Often essential components within the overall system, the compressors themselves must be produced to the highest quality standards and durable enough to withstand the extreme conditions of temperature and dust levels.

### What are Sauer compressors used for?

- Descalers – descaling
- Raising pressure for steel presses
- Argon and nitrogen for carbon treatment

### Who are Sauer Compressors' customers?

- Steelworks operators
- Manufacturers of machinery used on steel production lines
- Manufacturers of steel presses
- Engineering offices

### Which Sauer product ranges are used?

Product ranges: HURRICANE, 5000, 6000

Variants: Basic, BasBooster, BasSeal, ComSilent, ComBooster, ComSeal

Volumetric flow: 30 – 2000 m<sup>3</sup>/hr

Pressure range: 16 – 400 bar (g)

Medium: Air, nitrogen, argon



**In the naval sector**, Sauer is an established name as it is the world market leader for high-pressure compressors. However, the company's compressors impress not only on water but also on land. They are used in a variety of defence contexts, for example at naval ports and air-force bases as well as by ground troops. Highly flexible, Sauer compressors are available with a range of design options, whether you are simply looking for a particular colour scheme or require certification in accordance with military standards.

### **Our customers benefit from the following advantages:**

- The very latest compressors, control systems, compressed-air treatment systems and accessories
- Optimum customer services starting with the initial enquiry and extending over the entire life of the product
- 100% compressor check at final pressure including 3.1 approval certificate
- Long operating life with guaranteed availability of replacement parts (minimum 25 years)
- Turn-key solutions produced in accordance with customers' specifications
- NATO-codified compressors and replacement parts
- Compact design and extremely straightforward operation

### **What are Sauer compressors used for?**

- Naval ports – dockside air, e. g. for submarines
- Air-force bases – automatic operation systems e. g. weapon Systems for F15, F16, CASA C-295, Hercules, MiG 29
- Ground troops – nitrogen service for rocket control

### **Who are Sauer Compressors' customers?**

- Air forces
- Navies
- Ground troops

### **Which Sauer product ranges are used?**

Product ranges: PASSAT, HURRICANE, 5000, 6000  
Variants: Basic, BasBooster, ComSilent, ComBooster  
Volumetric flow: 30 – 2000 m<sup>3</sup>/hr  
Pressure range: 16 – 400 bar (g)  
Medium: Air, nitrogen

**With their robust construction** and straightforward operation, Sauer compressors are able to cope even with the demanding situations encountered in the underground mining business. Regardless of whether you require an ATEX-compliant specification or hydraulic motor drive, this is not a problem for Sauer's medium and high-pressure compressors. And if you require a mobile design, Sauer compressors are also available equipped with a diesel engine and a container unit for use anywhere in the world.

**Our customers benefit from the following advantages:**

- The very latest compressors, control systems, compressed-air treatment systems and accessories
- Optimum customer services starting with the initial enquiry and extending over the entire life of the product
- 100% compressor check at final pressure including 3.1 inspection certificate
- Long operating life with guaranteed availability of replacement parts (minimum 25 years)

**What are Sauer compressors used for?**

- Drilling deep boreholes

**Who are Sauer Compressors' customers?**

- Mines/mining companies
- Drilling companies

**Which Sauer product ranges are used?**

Product ranges: PASSAT, HURRICANE, 6000

Variants: Basic, BasSeal, ComSilent, ComSeal

Volumetric flow: 80 – 2000 m<sup>3</sup>/hr

Pressure range: 16 – 400 bar (g)

Medium: Air, nitrogen



## Safety

In situations where safety depends on high product availability, robust high-pressure compressors are needed. This is precisely why Sauer compressors are used for applications such as supplying breathing air or for fire-extinguishing systems, where they may be required to operate permanently under the most extreme conditions. Rather than making compromises, customers from the safety sector rely on compressors with the "Made in Germany" seal of quality.

### Our customers benefit from the following advantages:

- The very latest compressors, control systems, compressed-air treatment systems and accessories
- Optimum customer services starting with the initial enquiry and extending over the entire life of the product
- 100% compressor check at final pressure including 3.1 inspection certificate
- Long operating life with guaranteed availability of replacement parts (minimum 25 years)
- Robust designs to withstand even the most extreme conditions (55°C ambient temperature)
- Minimal downtimes – high product availability
- Compressors designed for permanent operation (S1 – 24/7)
- Compact design and extremely easy to use

### What are Sauer compressors used for?

- Stationary fire-extinguishing systems
- Supplying breathing air

### Who are Sauer Compressors' customers?

- Manufacturers of fire systems
- Company fire brigades and public fire stations
- Large diving centres

### Which Sauer product ranges are used?

Product ranges: PASSAT, HURRICANE, TORNADO, 6000

Variants: Basic, BasBreath, BasSeal, ComSilent, ComBreath, ComSeal

Volumetric flow: 10 – 2000 m<sup>3</sup>/hr

Pressure range: 40 – 411 bar (g)

Medium: Air, nitrogen, argon, carbon dioxide

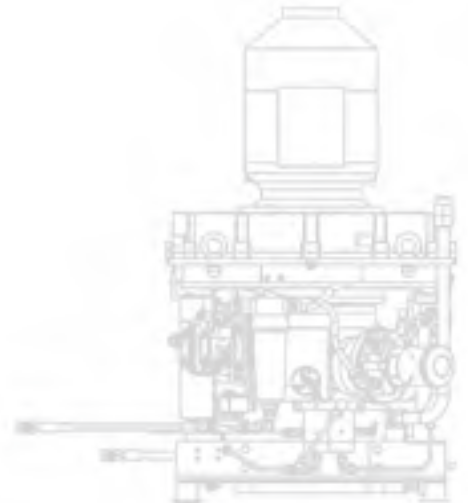

**The aviation industry is under considerable pressure** to keep costs down yet at the same time is faced with ever-increasing safety demands. Thankfully, the use of Sauer's medium and high-pressure compressors can help in both these areas. The costs of running aircraft fleets can be minimised by using nitrogen to inflate aircraft tyres, whilst the compressors' long maintenance intervals (MTBF) enhance this effect. The option of combining a variety of different drive systems as well as the units' compact design have a further positive effect, allowing the compressors to be moved around and used on airport aprons.

**Our customers benefit from the following advantages:**

- The very latest compressors, control systems, compressed-air treatment systems and accessories
- Optimum customer services starting with the initial enquiry and extending over the entire life of the product
- 100% compressor check at final pressure including 3.1 inspection certificate
- Long operating life with guaranteed availability of replacement parts (minimum 25 years)
- Robust designs to withstand even the most extreme conditions (55°C ambient temperature)
- Great reliability, even during intermittent operation
- Compact design and extremely easy to use



**What are Sauer compressors used for?**

- Inflating aircraft tyres using nitrogen
- Starting turbines
- Supplying aircraft systems

**Who are Sauer Compressors' customers?**

- Airport operators
- Air-force bases
- Engineering offices

**Which Sauer product ranges are used?**

Product ranges: PASSAT, HURRICANE

Variants: Basic, BasBooster,  
ComSilent, ComBooster

Volumetric flow: 80 – 120 m<sup>3</sup>/hr

Pressure range: 40 – 350 bar (g)

Medium: Air, nitrogen

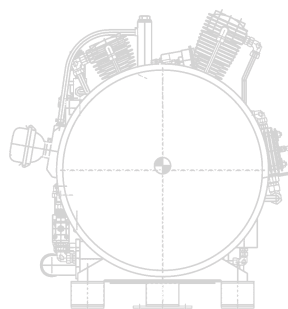



## Missing a solution for your application?

Do not hesitate to contact us!  
[solution@sauercompressors.de](mailto:solution@sauercompressors.de)



For further information  
please scan with your  
smartphone or tablet.

Your local agent:

**J.P. Sauer & Sohn Maschinenbau GmbH**  
P.O. Box 92 13, 24157 Kiel/Germany

PHONE +49 431 3940-0  
FAX +49 431 3940-24  
E-MAIL [info@sauercompressors.de](mailto:info@sauercompressors.de)  
WEB [www.sauercompressors.com](http://www.sauercompressors.com)

We reserve the right to make technical changes without prior notice.  
Please visit [www.sauercompressors.com](http://www.sauercompressors.com) for the latest version of the brochure.

**02/2013** [suw | s+k], pictures: S. Hofschlaeger/Pixelio.de; Renard; Simon Ebel, jongd, Mehmet Dilsiz, Afunbags, Frank Röder, Digishooter, Werner Weber, efired, Marc Pinter, Janusz Dymidziuk, LianeM, flashpics, strippenzieher, geargodz, Rafael Ben-Ari, Thomas Sztanek, Mikalai Bachkou, Alterfalter, Roman Milert, federico igea, Leonid Ikan, Luftbildfotograf, yang yu, lightpoet, Jim Parkin, benamalice – alle Fotolia.com; SMNG Murmansk, Russia; Seadrill; Nikolay Zaburdaev, Jim Parkin, PL-Pix, Dmitry Nikolaev, Snuckles – alle Fotolia.com; BAE Systems; Luca Flor, Rostislav Ageev, benjaminolte, Visionär, Pawel Klisiewicz – alle Fotolia.com

